

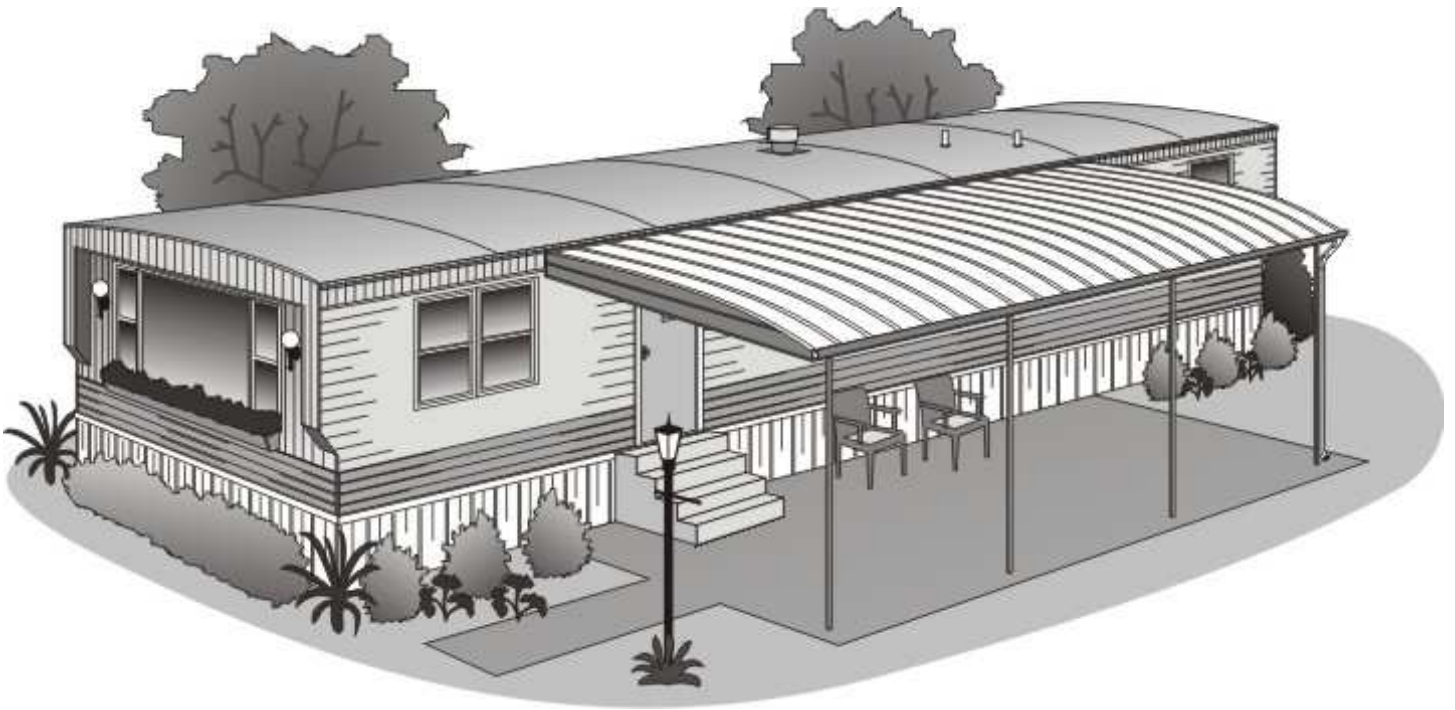

# AWNING / PATIO COVER

## INSTALLATION INSTRUCTIONS



### Before You Begin

Read the installation instructions thoroughly *before* beginning the installation procedure.

### Perspective

In the Awning Instructions, “Back” means toward the home, “Front” means away from the home, “Right” means the right side when facing the home, and “Left” means the left side when facing the home.

In general, we will begin assembling the Awning from the right to the left. The normal slope per foot of projection for the Awning is 1-1/2” or greater. The minimum slope is 1-1/3” per foot of projection. Anything less than 1-1/3” may cause water to flow toward the home. Clearance above a door should be a minimum of 6” to assure that the Awning will not interfere with the opening of the door.

### Tools Needed

Drill, 1/8” and 5/32” Drill Bits, 1/4” Masonry Bit, 5/16” and 1/4” Nut Drivers, Level, Hack Saw, Shears, Vise Grip or Clamp.

## Step 1 – Mounting Rail

Create a level line where the Awning is to be attached to the home. Sometimes, it is desirable to match the profile of the home rather than a level line. It is best to install the Mounting Rail as close to the top of the home as possible for there is usually structural material to attach to at that point. It also provides the best snow and wind profile for the Awning.

The drip rail on the home may have to be removed. If the drip rail is not removed, allow a 1" to 2" space between the drip rail and the Mounting Rail so that caulk may be applied above the Mounting Rail. Place Sealing Tape on the back of the Mounting Rail covering the holes. Fasten the Mounting Rail to the home with #10 x 1-1/2" Hex Head Screws following the reference line.

Secure all screws through the Mounting Rail and into structural material on the home. It may be necessary to drill extra holes in the Mounting Rail so that the screws can secure into structural material. Caulk the top of the Mounting Rail between the rail and the home to prevent any water from entering behind the rail.

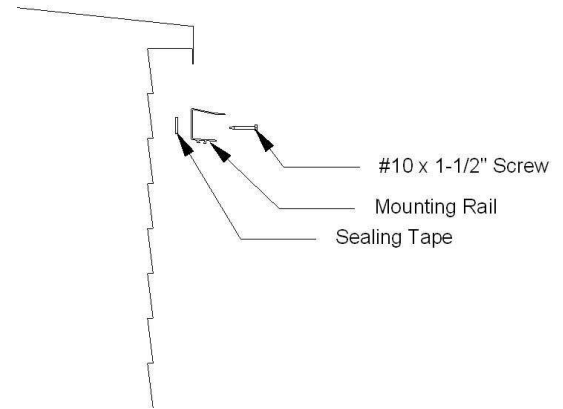

## Step 2 – Drilling Awning Panels (To locate Support Channel and Gutter)

Determine how far from the front of the Awning the Support Channel is to be located. Measure that distance on the drilling template and drill a 5/32" hole on the scored line. The minimum set back is 6" and the maximum is 16".

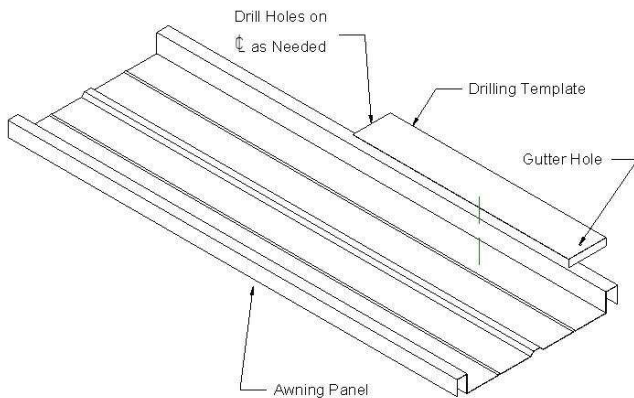

Place the drilling template on the end of the panel with the clip end pointing downward and slide it flush against the inside of the panel rib on the right side. The predrilled hole closest to the clip end of the template will locate the attachment of the gutter. Mark these two holes with a pencil and repeat the procedure for the left side of the panel, keeping the template against the inside of the rib. Mark all of the remaining awning panels in the same manner. Drill a 5/32" hole through the awning panels where they have been marked.

## Step 3 – Support Channel and Joiner

The Support Channel comes in 10' lengths. The left end piece of Support Channel is marked with a tag "Left End" and has been trimmed by the factory 3/4" or more.

Lay out all sections of Support Channel with the shortened section at the left end. Be sure that the Support Channel is facing forward. Turn the Support Channel upside down. Where one section butts against another section, insert a Support Channel Joiner so that it is even on both sides. Secure with #10 x 1/2" TEK Screws through the Support Channel and Support Channel Joiner, two on the front side and two on the backside of each section of Support Channel. **BE SURE THAT THE SUPPORT**

**CHANNEL JOINER IS AGAINST THE INSIDE LEGS OF THE SUPPORT CHANNEL AND THAT THE TWO SECTIONS THAT BUTT TOGETHER ARE EVEN.**

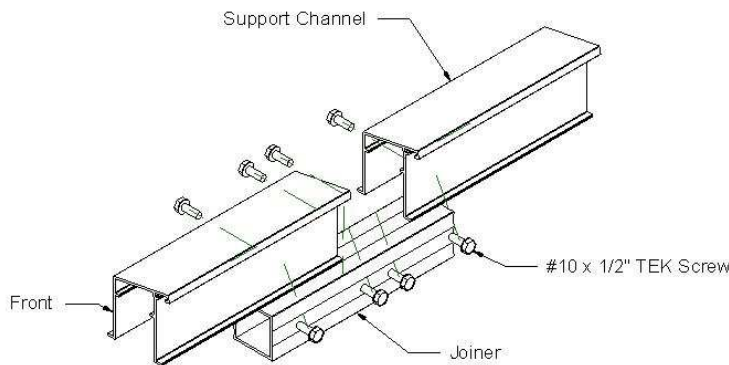

### Step 4 – Post Assembly

Determine the desired height of the posts. Normal slope is about 1-1/2" of slope per foot of projection. Insert the 30" section of the Post into the 84" section for form a Standard Telescoping Post. Where the sections join together, attach a vise grip or clamp to the smaller section. This will prevent the smaller section from sliding further into the large section. Assemble all posts in a similar fashion.

Position the end posts 6 – 12 inches in from each end of the Support Channel. Insert the small 1-1/4" sections of the Posts into the Support Channel until it stops. Secure with #10 x 1/2" TEK Screws through the front and back of the Support Channel and into the small section of the Post. Space the remaining posts equally between the end posts and secure to the Support Channel. If a post is spaced where a Support Channel Joiner is located, the post must be moved right or left to be installed.

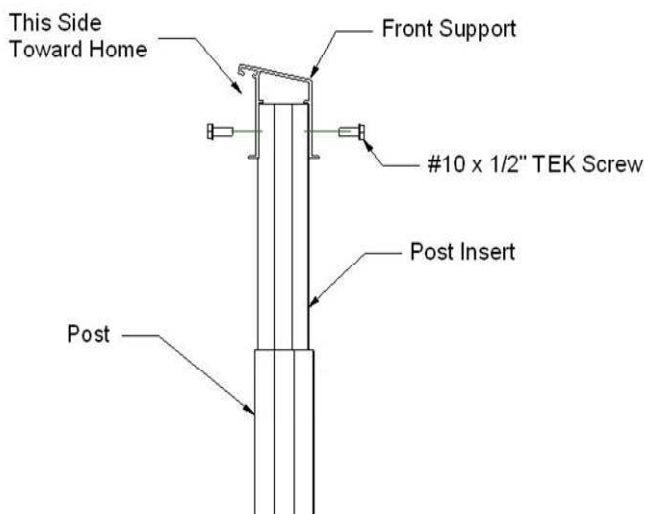

### Step 5 – Awning Panel Assembly

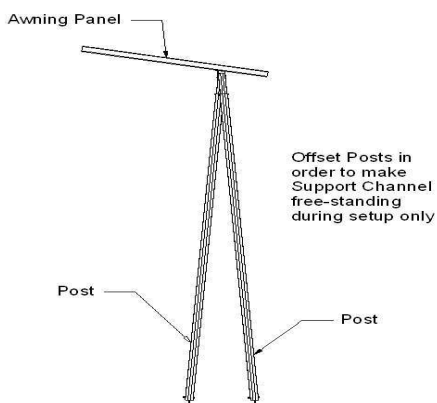

All Awning Panels are alike. Stand up the Support Channel by staggering the attached posts. The assembly of the Awning Panels must begin from the right side of the Mounting Rail. Insert the boxed end of the first Awning Panel into the Mounting Rail with the overlapping rib extending beyond the end of the Mounting Rail. The first panel may be secured in one of two places: 1) through the back of the boxed end of the panel and into the Mounting Rail, or 2) through the bottom of the Mounting Rail and into the panel surface. Use a #10 x 3/4" Hex Head Screw.

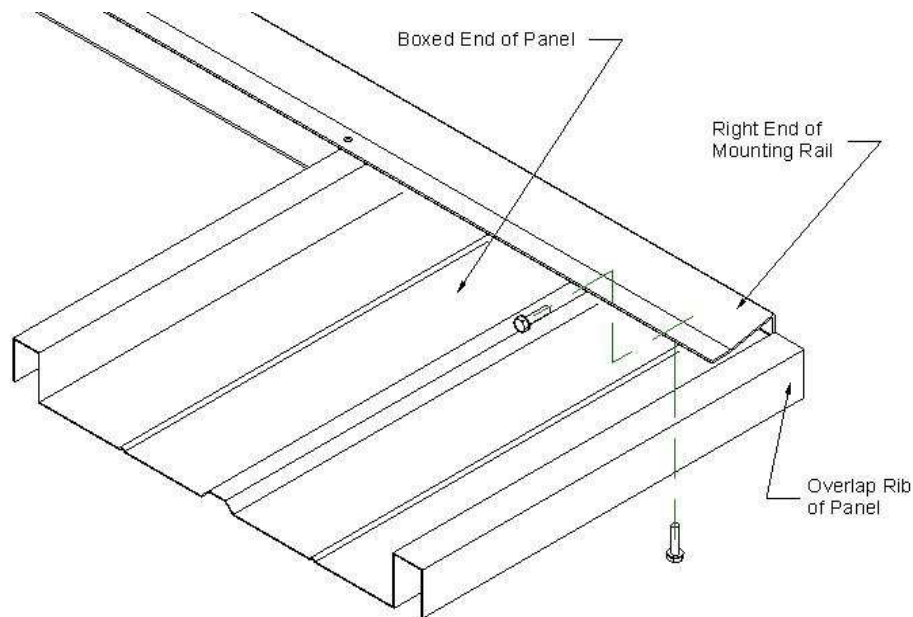

Insert the second Awning Panel into the Mounting rail, overlapping the adjoining rib. The overlapping rib of the second panel should be directly under the first pre-punched hole on the right side of the Mounting Rail. Secure the two panel ribs through the first hole with a #10 x 3/4" Hex Head Screw.

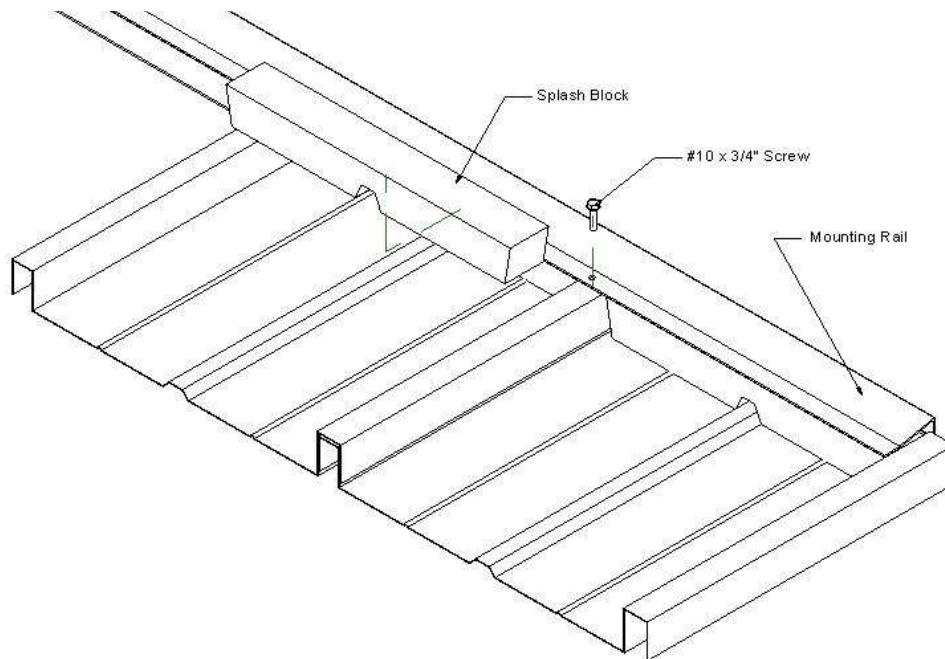

Insert a polystyrene splash block into the Mounting Rail between the two ribs on the first Awning Panel. The splash blocks have a tight, secure fit and by tilting them forward while inserting, will ease the process. Install the remaining Awning Panels and splash blocks in the same fashion by aligning the pre-punched holes in the Mounting Rail with the Awning Panel ribs. The last Awning Panel should be secure just as the first panel was, allowing the last panel rib to extend beyond the end of the Mounting Rail and Front Support Channel.

## Step 6 – Adjusting and Anchoring Patio Cover

Adjust the Patio Cover to the desired pitch and secure the two sections of each post in the front and back with #10 x 1/2" TEK Screws. After the posts are vertically leveled, mark their location. Move the post off the spot to allow location of an anchor.

### Concrete Anchor

Keep holes at least 2" in from the edge of the concrete to prevent cracking. Drill a 1/4" hole at least 2" deep in concrete. Put a nut and washer on the stud flush with the end of the threads. Insert the stud in the hole and tap so the nut and washer are flush with the concrete. Tighten the nut about 4 turns to expand the base of the stud. Remove the nut and washer from the Rawl-Stud and place a post bracket over the stud. Replace the washer and nut and tighten. Place the post over the bracket and secure with a 1/4" x 1-3/4" bolt and nut.

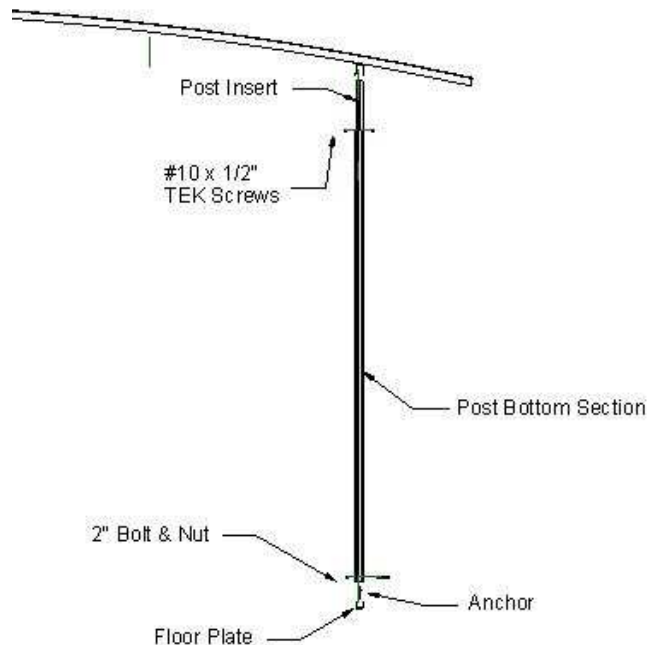

### Wood Lag

Drill 1/8" hole in wood. Place post bracket over hole and screw wood lag into hole to start threads. Continue post attachment.

### Ground Anchor

Drive the ground anchor into the ground until the slotted hole meets the ground. Insert the locking pin about 3" through this hole. Continue to drive the pin anchor until the second hole is at proper height for mounting posts. Drive the locking pin through the anchor until it is flush with the ground.

### Scroll Post

Attach the base of the scroll post to the concrete with a 1/4" x 5/8" anchor and nut.

## Step 7 – Gutter and Front Trim

Gutter comes in 10' sections. One section of the Gutter has been shorted 3/4" or more to allow the right and left end Awning Panel ribs to extend beyond the Gutter. The right and left end pieces of Gutter have a hole provided for the downspout adapter. These holes are located 10" from the end of the Gutter to allow the downspout to align with a post. Attach the End Cap in the Gutter with two #8 x 3/4" Hex Head Screws and then caulk the End Cap on the inside of the Gutter to prevent leaks. Note that the Gutter Insert Trim is long enough overall to allow it to cover the End Cap if desired. Insert a section of Front Trim into the back of the Gutter and secure with #10 x 1/2" TEK Screws. Do not place a screw within 2" of the end of the Front Trim for it may interfere with a later procedure.

Place a Gutter Joiner in the Gutter Section half way so that it will accommodate the next section of Gutter. Secure the Gutter Joiner to the Gutter Section with #10 x 1/2" TEK Screws through the Gutter and into the Gutter Joiner. Insert the next gutter section and secure in the same manner. Two screws in the bottom and two screws in the back of the gutter will eliminate the need for more screws through the Gutter Insert Trim. Caulk the Gutter Joiner in the Gutter Section.

Install the first section of Gutter using #10 x 3/8" Snub Nose Screws through the drilled hole in the Awning Panel and into the screw track at the back of the Gutter. Do not over torque. The right end of the Gutter should be even with the inside leg of the right rib of the right end Awning Panel. This will allow the rib to extend beyond the Gutter on both ends of the Awning. Install the remaining section of Gutter in the same fashion, butting the Gutter Sections and connecting with a Gutter Joiner. Make sure that all joints are caulked and water tight.

Adjust the Gutter Insert Trim in the entire Gutter for best appearance. Insert the Front Trim Joiner into the back of the Front Trim's rib and secure with #8 x 3/4" Hex Head Screws.

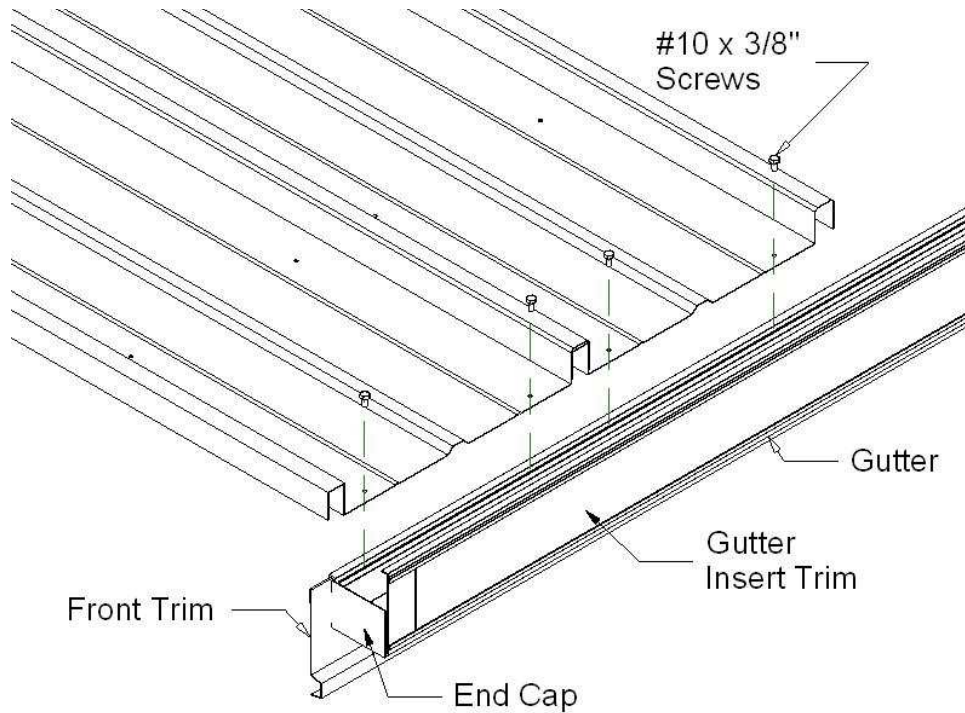

### Step 8 – Right and Left

There are two valances "Right" and "Left". Insert the appropriate valance into the outside rib on the appropriate end of the Awning. The valances are manufactured longer than the Awning projection to allow a custom fit against the home. The tab on the front or smaller end of the valance is designed to fit between the Front Trim and the Gutter. Cut the back of larger end of the valance to allow it to fit against the home. Some installers prefer to bend a tab at the home from the excess material which they secure to the home after the valance is installed. Attach the valance to the inside leg of the last rib so that they are not visible from the outside. Secure the front end of the valance between the Front Trim and the Gutter with #8 x 3/4" Screws.

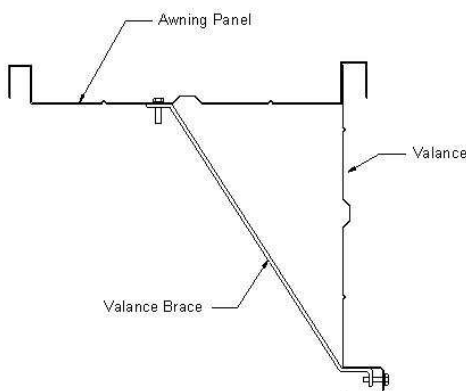

Attach the Trim Brace to the inside of the rib in the Valance with #8 x 3/4" Screws. Run the screw through the valance and into the Brace for a strong hold. Align the Valance vertically and drill through the top hole in the Trim Brace up through the Awning Panel. Secure top of Trim Brace with #10 x 3/4" Screws installed through the Awning Panel into the Trim Brace.

Install Awning Corner Trim with #8 x 3/4" Screws.

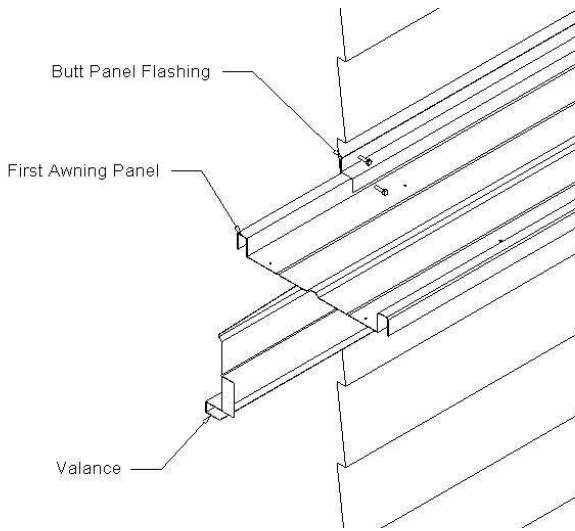

When the side of a patio cover is attached to an expando, the Valance may be cut just inside the outer edge of the expando and attached to the home or the complete side trim can be used. Butt panel flashing is used to flash the first panel rib to the side of the home.

Cut the top and bottom rib on the butt panel flashing to accommodate for the arch. Place a quality caulk/sealant on the back of the top and bottom rib on the butt panel flashing and attach to the home as needed using #10 x 3/4" Hex Head Screws.

### Step 9 – Downspout (Read entire section first)

Secure the Downspout Adapter to the bottom of the Gutter covering the hole provided. Secure in place with #10 x 1/2" TEK Screws. When no downspout hole is provided, secure a Downspout Adapter to the Gutter in the desired location and then cut a hole within the area outlined by the Downspout Adapter.

Three Downspout Elbows are provided to allow the downspouts to be set back and to provide a kick out at the bottom. The 7' downspout may be cut if the set back distance is greater than the distance of the two elbows. Secure each section with #8 x 3/4" screws. Each downspout section should be secured with the downspout straps provided. Excess strap material should be removed.

